

Safety Switches with Separate Actuator, Metal Housing **EUCHNER**

Selection table for safety switches STA with guard locking and guard lock monitoring

Release feature				
HE	Mechanical release on the front			
	Door monitoring			
	STA3/4		STA1/2	With door monitoring contact
				Without door monitoring contact
			Connection	
			M	Thread M20x1.5 for cable gland



Release feature	Door monitoring		Connection	Page
HE	STA3/4	STA1/2	M	
●	●		●	98
●		●	●	99

Safety switch STA with guard locking and guard lock monitoring

- ▶ Mechanical release on the front
- ▶ With door monitoring contact



Approach direction



Horizontal and vertical

Mechanical release

Is used for releasing the guard locking with the aid of a tool. The mechanical release must be sealed to prevent tampering (for example with sealing lacquer).

Solenoid operating voltage

- ▶ AC/DC 24 V +10%, -15%
- ▶ AC 110 V +10%, -15%
- ▶ AC 230 V +10%, -15%

Guard locking types

- STA3** Closed-circuit current principle, guard locking by spring force. Release by applying voltage to the interlocking solenoid.
- STA4** Open-circuit current principle, guard locking by applying voltage to the interlocking solenoid. Release by spring force.

Switching elements (see also page 13)

- ▶ **2131** Slow-action switching element
2 NC ⊖ + 1 NO + 1 NC (door monit. contact)
- ▶ **4121** Slow-action switching element
2 NC ⊖ + 1 NC / 1 NO (door monit. contact)
- ▶ **4131** Slow-action switching element
2 NC ⊖ + 1 NO + 1 NO (door monit. contact)
- ▶ **4141** Slow-action switching element
2 NC ⊖ + 2 NC (door monit. contacts)

Cable entry M20 x 1.5

Dimension drawing

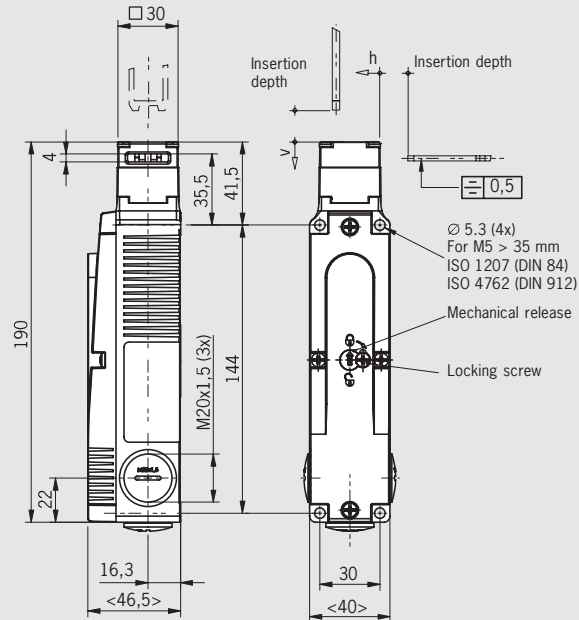

Please order actuator separately (see page 108)

For cable glands see page 115

Wiring diagrams Actuator inserted and locked

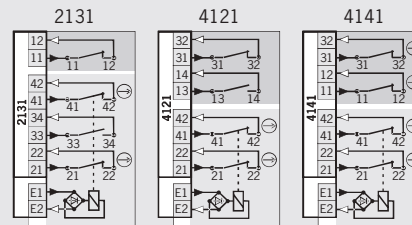

Solenoid monitoring
 Door monitoring

Ordering table

Series	Connection	Guard locking	Switching element	Version	Solenoid operating voltage	
					AC/DC 24 V	
STA	M Cable entry 3 x M20x1.5	3 Mechanical	2131 2 NC ⊖ + 1 NO + 1 NC		096 938 STA3A-2131A024M	
			4121 2 NC ⊖ + 1 NC / 1 NO		096 936 STA3A-4121A024M	
			4141 2 NC ⊖ + 2 NC		099 274 STA3A-4131A024M	
		4 Electrical	2131 2 NC ⊖ + 1 NO + 1 NC		096 939 STA4A-2131A024M	
			4121 2 NC ⊖ + 1 NC / 1 NO		096 937 STA4A-4121A024M	

Safety switch STA with guard locking and guard lock monitoring

- ▶ Mechanical release on the front
- ▶ Without door monitoring contact



Approach direction



Horizontal and vertical

Mechanical release

Is used for releasing the guard locking with the aid of a tool. The mechanical release must be sealed to prevent tampering (for example with sealing lacquer).

Solenoid operating voltage

- ▶ AC/DC 24 V +10%, -15%
- ▶ AC 110 V +10%, -15%
- ▶ AC 230 V +10%, -15%

Guard locking types

- STP1** Closed-circuit current principle, guard locking by spring force. Release by applying voltage to the interlocking solenoid.
- STP2** Open-circuit current principle, guard locking by applying voltage to the interlocking solenoid. Release by spring force.

Switching elements (see also page 13)

- ▶ **4131** Slow-action switching element
2 NC \ominus + 2 NO

Cable entry M20 x 1.5

Dimension drawing

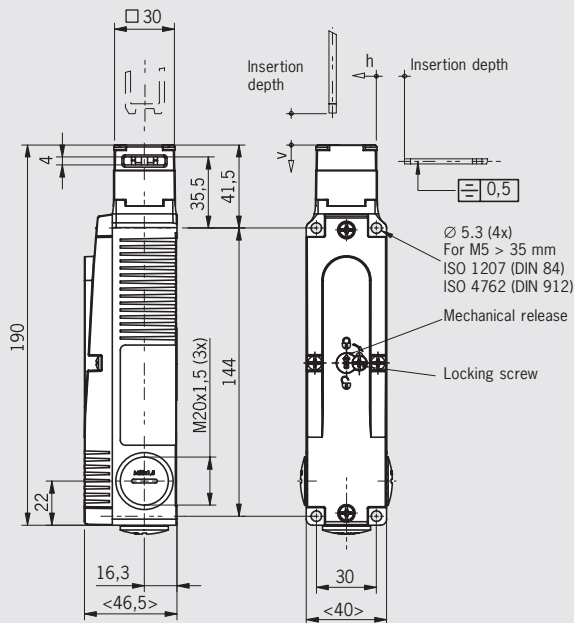

Wiring diagrams Actuator inserted and locked

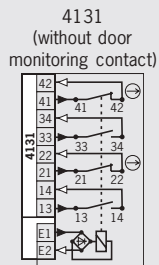

- Solenoid monitoring
- Door monitoring

Ordering table

Series	Connection	Guard locking	Switching element	Version	Solenoid operating voltage	
					AC/DC 24 V	
STA	M Cable entry 3 x M20x1.5	1 Mechanical	4131 2 NC \ominus + 2 NO		096 439 STA1A-4131A024M	
		2 Electrical	4131 2 NC \ominus + 2 NO		096 935 STA2A-4131A024M	





Safety switch STA... with guard locking and guard lock monitoring



The technical data on switches, switching elements and guard locking apply to all connections. Further technical data are given for the connection selected.

Switch			
Parameter	Value		Unit
Housing material	Anodized die-cast		
Mechanical life	1 x 10 ⁶ operating cycles		
Ambient temperature	- 20 ... + 80		°C
Weight	Approx. 0.6		kg
Max. approach speed	20		m/min
Actuating force	35		N
Extraction force (not locked)	30		N
Retention force	20		N
Locking force, max.	Approach direction		
	From top (v)	Side (h)	
	2500	2500	N
Locking force F _{Zn} in accordance with test principles GS-ET-19	Approach direction		
	From top (v)	Side (h)	
	2000	2000	N
Insertion depth (minimum required travel + permissible overtravel)	Standard actuator S	Actuator L for insertion funnel	
Approach direction side (h)	24.5 + 5	28.5 + 5	mm
Approach direction from top (v)	24.5 + 5	28.5 + 5	mm

Switching element			
Parameter	Value		Unit
Switching principle	Slow-action switching element		
Switching elements	2131	4121	4131
with 4 switching elements	2 NC + 1 NO + 1 NC	2 NC + 1 NC + 1 NO	2 NC + 2 NO
Switching current, min., at 24 V DC	1		mA
Switching voltage, min., at 10 mA	12		V
Contact material	Silver alloy, gold flashed		

Guard locking			
Parameter	Value		Unit
Solenoid operating voltage	AC/DC 24 V +10/-15%		
Connection	Reverse polarity protected, integrated bridge rectifier		
Duty cycle ED	100		%
Power consumption	8		W

Connection, cable entry M20 x 1.5			
Parameter	Value		Unit
Connection	Screw terminal		
Version	M20 x 1.5		
Conductor cross-section max.	0.34 ... 1.5		mm ²
Degree of protection according to IEC 60529	IP 67		
Rated impulse withstand voltage U _{imp}	2.5		kV
Rated insulation voltage U _i	250		V AC/DC
Conventional thermal current I _{th}	4		A
Short circuit protection according to IEC 60269-1 (control circuit fuse)	4		A gG
Utilization category to IEC 60947-5-1	AC15	le 4 A Ue 230 V	
	DC13	le 4 A Ue 24 V	

**Switching functions STA1/STA2
without door monitoring contact**

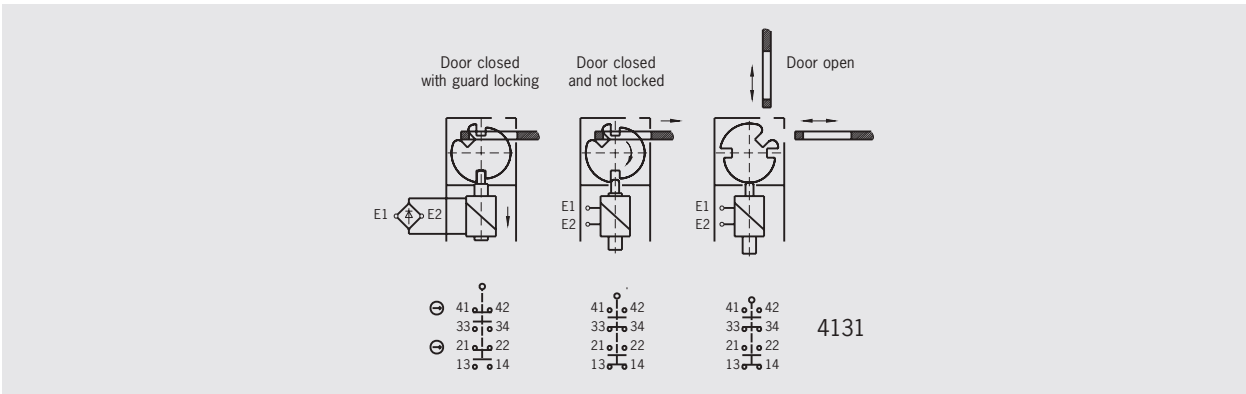

**Switching functions STA3/STA4
with door monitoring contact**

