

Non-contact safety switches CES-A-S5H-01

- ▶ Read head with integrated evaluation electronics
- ▶ Position detection (15 positions)
- ▶ Switching of clocked signals possible
- ▶ 2 safety outputs (semiconductor outputs)
- ▶ Category 4 / PL e according to EN ISO 13849-1

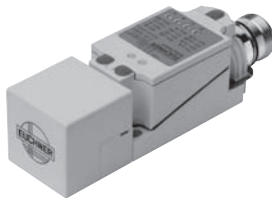

For possible combinations see page 79

Approach direction

Can be adjusted in 90° steps

Position detection

The safety switch CES-A-S5H-01 is suitable for the detection of 14 different position actuators and one safety actuator.

Category according to EN ISO 13849-1

Due to two redundant design semiconductor outputs (safety outputs) with internal monitoring suitable for:

- ▶ Category 4 / PL e according to EN ISO 13849-1

LED display

STATE	Status LED
OUT/ERROR	Status safety output/ diagnostic LED (combined)
D0...D3	Position indicator

Additional connections

D0...D3 Data outputs (semiconductor)

Warning:

The operating distance may vary depending on the background material and installation situation.

Note:

- ▶ Screened connection cables must be used for the connection.
- ▶ For detailed information on planning, please refer to the System Manual in the Internet at www.euchner.de (document no. 095710).

Ordering table

Series	Category according to EN ISO 13849-1	Order no. / item
CES-A-S5H-01	4 / PL e	090 640 CES-A-S5H-01

Non-contact safety switch CES-A-S5H-01

M23 plug, 12-pin

Cat.
3/4
PLe

Dimension drawing

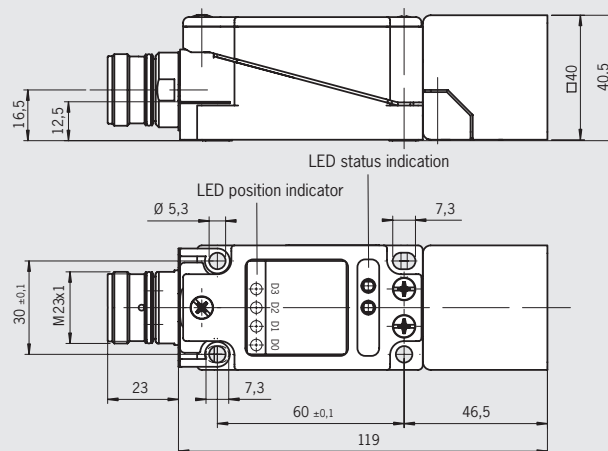

For mating connectors see page 88

Block diagram

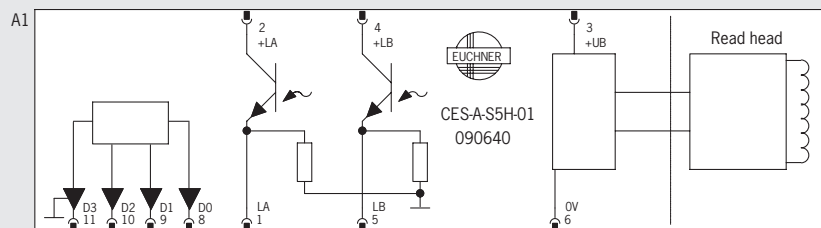

Pin assignment

1 ▶ LA	7 ▶ NC
2 ▶ +LA	8 ▶ D0
3 ▶ +UB	9 ▶ D1
4 ▶ +LB	10 ▶ D2
5 ▶ LB	11 ▶ D3
6 ▶ 0V	12 ▶ NC

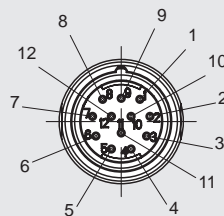

View on the connection side of the safety switch

Typical operating distance

With actuator CES-A-BBA
(also applies for position actuator)

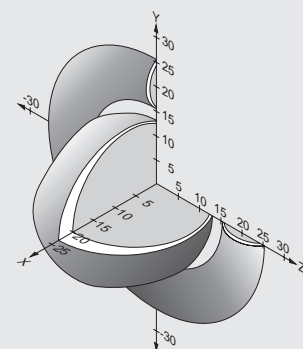

For a side approach direction for the actuator and read head, a minimum distance of $s = 3$ mm must be maintained so that the operating distance of the side lobes is not entered.

Technical data non-contact safety switches CES-A-S5H-01

Parameter	Value			Unit
	min.	typ.	max.	
Housing material	Plastic PBT V0 GF20			
Dimensions	According to EN 60947-5-2			mm
Weight	0.4			kg
Ambient temperature at $U_b = DC 24 V$	-20	-	+55	°C
Degree of protection	IP67			
Degree of contamination	3			
Installation position	Any			
Connection type	M23 plug connector, 12-pin			
Operating voltage U_b (regulated, residual ripple < 5 %)	18	24	27	V DC
Current consumption	50			mA
External fuse (operating voltage U_b)	0.25	-	8	A
Power supply for load $U(+LA)/U(+LB)$	18	-	27	V DC
Classification according to EN 60947-5-3	PDF-M			
EMC protection requirements	In acc. with EN 60947-5-3			
Safety outputs (LA / LB, 2 semiconductor outputs, p-switching, short circuit-proof, electrically decoupled) - Output voltage $U(LA)/U(LB)$ ¹⁾				
HIGH U(LA)	$U(+LA) - 1.5$	-	$U(+LA)$	V DC
HIGH U(LB)	$U(+LB) - 1.5$	-	$U(+LB)$	
LOW U(LA)/U(LB)	0	-	1	
Switching current per safety output	1	-	400	mA
External fuse $U(+LA)/U(+LB)$, safety circuit	400 mA medium slow-blow			
Utilization category acc. to EN 60947-5-2	DC-13 24V 400mA			
Classification according to EN60947-5-3	PDF-M			
Rated insulation voltage U_i	-	-	30	V
Rated impulse withstand voltage U_{imp}	-	-	1.5	kV
Resilience to vibration	According to EN 60947-5-2			
Switching delay from state change ²⁾	-	-	180	ms
Difference time between the two safety outputs	-	-	120	ms
Ready delay ³⁾	-	-	3	s
Dwell time ⁴⁾	0.5	-	-	s
Switching frequency	-	-	1	Hz
Repeat accuracy R according to EN IEC 60947-5-3	≤ 10			%
Data outputs (D0, D1, D2, D3) Semiconductor push-pull outputs short circuit-proof				
- Output voltage HIGH	$0.8 \times U_b$	-	U_b	V DC
- Output voltage LOW	0	-	2	
Load current per output	-	-	20	mA
Ready delay ³⁾	-	-	3	s
Switch-on delay from state change (with position actuators)	4	-	9	ms
Switch-off delay from state change (with position actuators)	-	200	-	ms
Relative speed with position actuators	-	-	2	m/s
With permissible read distance s	6	-	10	mm
Mounting distance between position actuators or position actuators and safety actuators	80	-	-	mm
In combination with actuator CES-A-BBA/CES-A-BCA				
Operating distance for center offset $m = 0$				
- Switch-on distance	-	20	-	mm
- Assured switch-on distance s_{on} ⁵⁾	15	-	-	
- Switching hysteresis ⁵⁾	2	3	-	
- Assured switch-off distance s_{off}	-	-	40	
In combination with actuator CES-A-BPA				
Operating distance for center offset $m = 0$				
- Switch-on distance	-	22 ⁶⁾	-	mm
- Assured switch-on distance s_{on}	15	-	-	
- Switching hysteresis ⁵⁾	1	2	-	
- Assured switch-off distance s_{off}	-	-	58	
LED displays	STATE OUT/ERROR OUT/ERROR	Green LED: flashing: Yellow LED: Red LED:	Normal operation Teach-in operation Actuator detected - EMC interference - Internal electronics fault - Invalid teach-in operation	
Reliability figures according to EN ISO 13849-1				
Category	4			
Performance level (PL)	e			
PFH _d	$3.7 \times 10^{-9} / h$			
Mission time	20			years

1) Values at a switching current of 50 mA without taking into account the cable lengths.

2) Corresponds to the risk time according to EN 60947-5-3. This is the maximum switch-off delay for the safety outputs following removal of the actuator.

3) After the operating voltage is switched on, the semiconductor outputs are switched off and the monitoring outputs are set LOW during the ready delay.

4) The dwell time of an actuator inside and outside the operating distance must be at least 0.5 s to ensure reliable detection of internal faults in the evaluation unit (self-monitoring).

5) Values apply for surface mounting of the actuator.

6) On surface mounting on aluminum, in a non-metallic environment the typical switching distance increases to 30 mm.